

Standard Full Nut

Thread Type: BSF - Fine

Thread Direction: Right Hand

Material: Carbon Steel

Class Grade: High Tensile Grade 8

Finish: Zinc Plated

Corrosion Protection Level: Moderate

Standard: BS 1083:1965

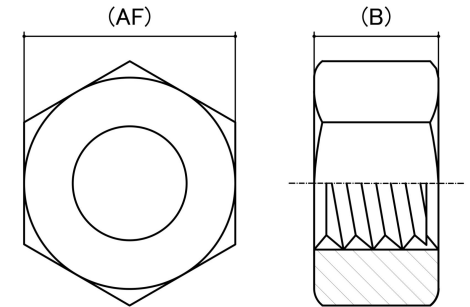

*CAD drawings shown for graphic representation only.**

Size	Thread Pitch (TPI)	Thread Type	Overall Nut Height (B) (mm)		Across Flats (AF) (mm)		Spanner Size (AF) (inches)	sku (qfind)
			Min	Max	Min	Max		
1/4"	26	Fine	4.83	5.08	11.13	11.30	7/16	41BSF14
5/16"	22	Fine	6.10	6.35	13.08	13.33	9/16	41BSF516
3/8"	20	Fine	7.67	7.92	15.04	15.24	9/16	41BSF38
7/16"	18	Fine	9.27	9.53	17.85	18.25	11/16	41BSF716
1/2"	16	Fine	10.85	11.10	20.62	20.83	7/8	41BSF12

Disclaimer:

Dimensional data and technical information was obtained from publically available sources and not acquired through standard agencies. It has been completed and compiled for reference purposes only; where discrepancies are found they are subject to change without notice. Bolt & Nut Australia makes no warranties or representations regarding the accuracy and validity of the compiled information and data. Contact the relevant standard authorities for accurate and detailed information.

* CAD drawings may not reflect diameter, thread length or overall length.

© Bolt & Nut Australia Pty Ltd. All rights reserved.

Version: 18 Mar 2024